

Indoor Type(Slim)

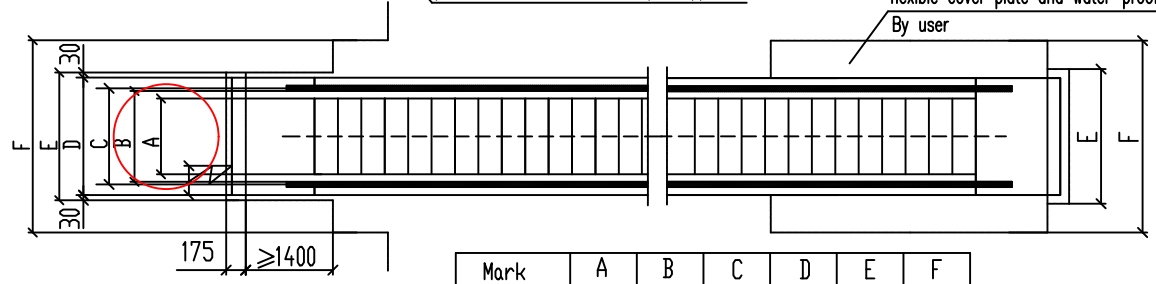
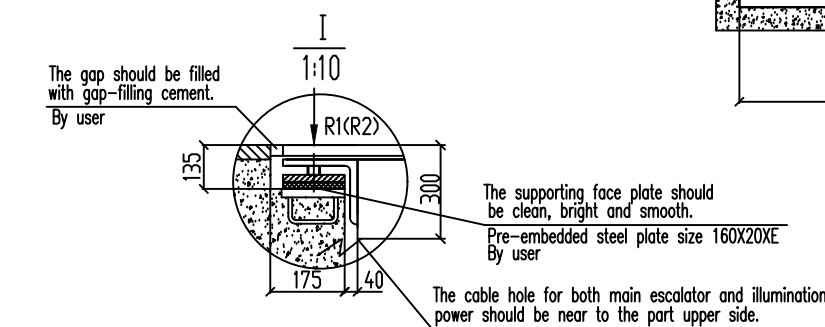
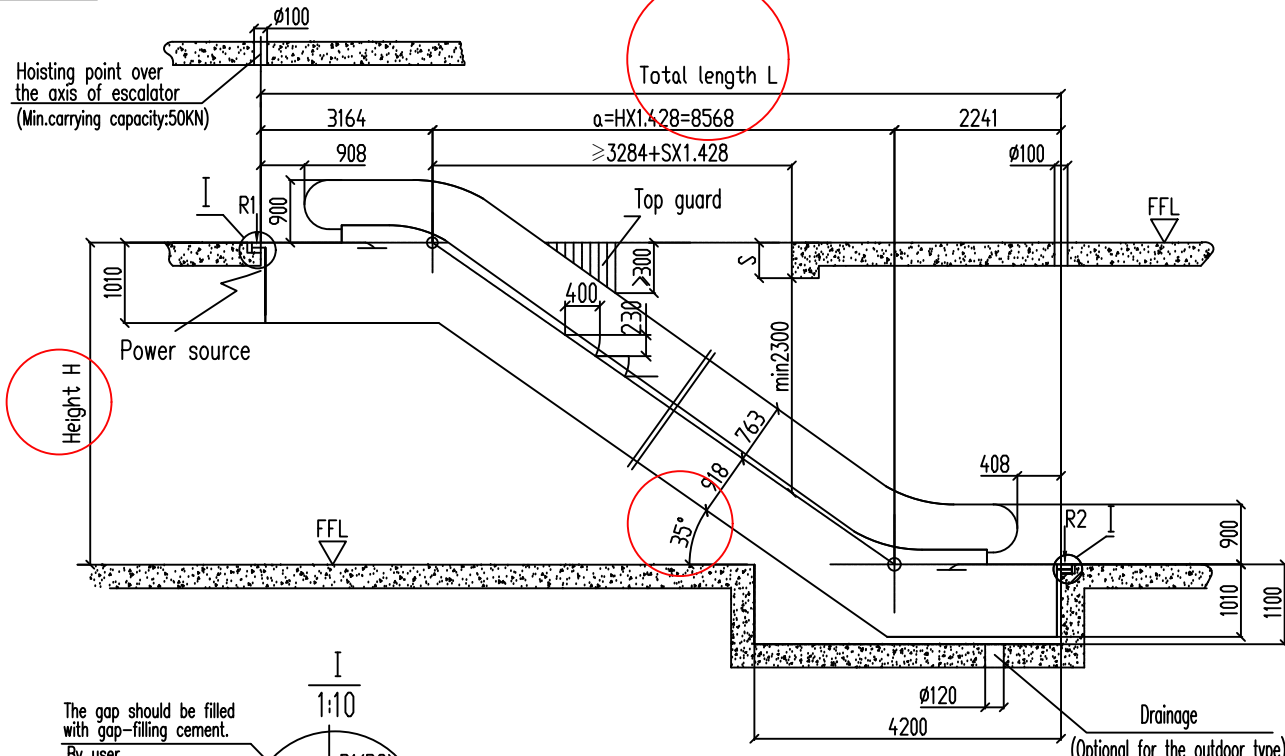

Mark	A	B	C	D	E	F
Width(mm)	600	758	838	1100	1150	>1250

ESCALATOR

Technical Description

BRAND	DIAI
Model	SME(600)-35
Vertical Rise(mm)	6000
Step Width(mm)	600
Inclined Degree	35
Speed(m/s)	0.5
Motor Power(KW)	7.5
Net Weight(KN)	74
Supporting Force(KN)	R1: 61 R2: 54

POINTS FOR ATTENTION

1. The pit is canceled when the escalator is installed just above the lowest floor.
  2. The upper and lower part of the escalator is symmetrical.
  3. The escalator entrance and exit should have an unblocked area. The width of this area should not be less than 838 mm. And the distance from the escalator handrail turning end to front obstacles should not be less than 2500mm.
  4. The distance from the escalator handrail to any obstacles should not be less than 500mm.
  5. Please refer to above table for the motor power. (AC380V 50HZ)
  6. The site's builder should provide three-phase five-wire power source to the escalator main switch.
  7. The site's builder should provide a ground device whose resistance will be less than 4Ω.
  8. mm is used as size unit of the drawing.
- Product technical requirements can be change in future without any further notice.

BUYER'S SEAL & SIGNATURE:

SELLER'S SEAL & SIGNATURE:

CUSTOMER			
CONTRACT NO.			
DRAWING NO.	DA20200416-01	DATE	2020-04-16
DRAWN BY	Mr. Xu Yaxia	APPROVED BY	Mr. Bo Jianlin